

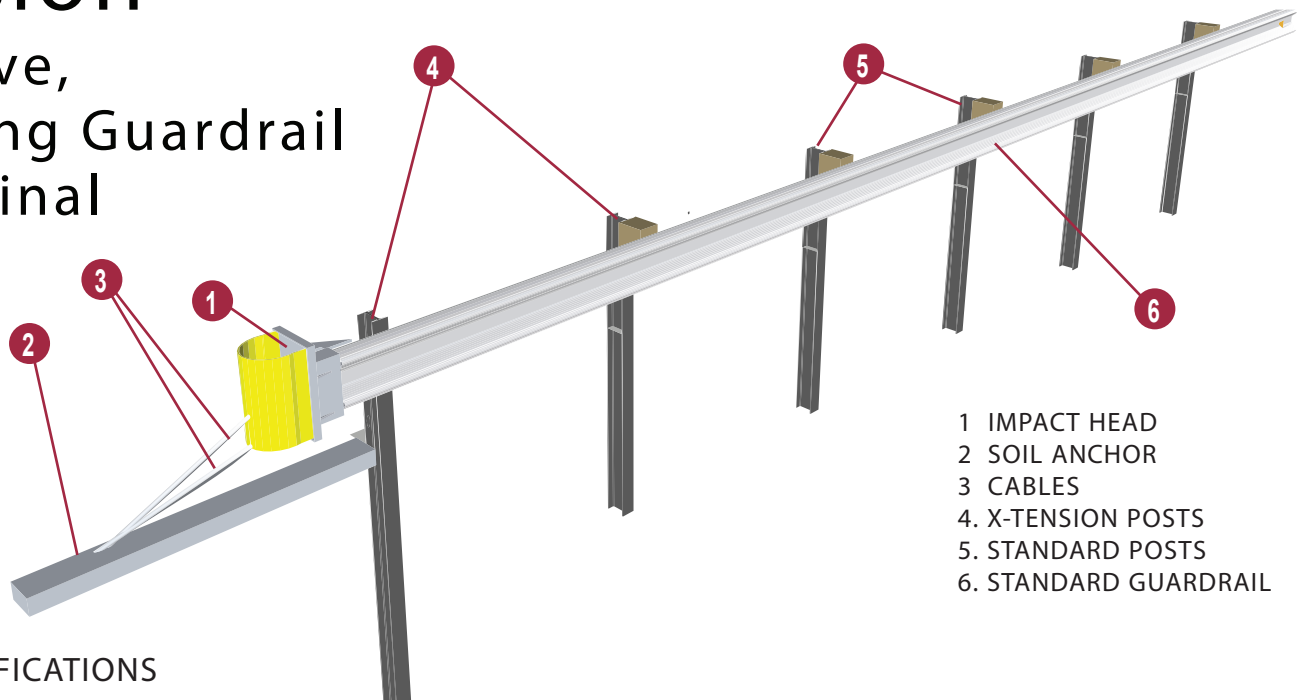

X-Tension™

Redirective, Non-Gating Guardrail End Terminal



- 1 IMPACT HEAD
- 2 SOIL ANCHOR
- 3 CABLES
- 4. X-TENSION POSTS
- 5. STANDARD POSTS
- 6. STANDARD GUARDRAIL

PHYSICAL SPECIFICATIONS

Length	12 m [40']
Width	572 mm [22.5"]
Height	727 / 787mm [28.5/31"]
Weight	534 kg [1179 lb]

FEATURES

- Only NCHRP 350 tested Redirective Non-Gating Guardrail Terminal available
- Available in 727 or 787mm [28.5 or 31"] heights
- Uses same components for tangent or flared applications
- Easy to install
- Utilizes many standard guardrail components

NCHRP 350 TL-3 REDIRECTIVE, NON-GATING GUARDRAIL END TERMINAL

The X-Tension Redirective, Non-Gating Terminal is the only Redirective, Non-Gating guardrail terminal in the market. The X-Tension Terminal has been engineered to be used interchangeably for flared and tangent roadside applications. This results in significant savings in inventory, repair and maintenance costs. The X-Tension Terminal uses standard guardrail components and is available with either wood or steel posts and with either wood or composite blockouts.



FREQUENTLY ASKED QUESTIONS

WHAT MAKES THE X-TENSION TERMINAL DIFFERENT FROM THE OTHER END TERMINALS ON THE MARKET?

The X-Tension Terminal is tested to NCHRP 350 as a Redirective Non-Gating System. All other terminals are tested as Redirective Gating Systems, meaning they will only start to redirect at the third post.

CAN THE X-TENSION TERMINAL BE ATTACHED TO CONCRETE BARRIER?

The X-Tension Terminal can be attached to concrete barrier with the addition of standard transitions.

IS A TRANSITION NEEDED TO ATTACH TO STANDARD GUARDRAIL?

The X-Tension Terminal is designed to attach directly to guardrail with no transition required.

CAN THE X-TENSION TERMINAL BE INSTALLED USING COMPOSITE BLOCKOUTS?

The X-Tension Terminal can be ordered with either wood or composite blockouts.

